

# DATASHEET

## MS7000.3 / Single axis analog accelerometer in TO8

30S.MS7XXX.J.05.11

Energy

Mil/Aerospace

Industrial

 Inertial

 Tilt

 Vibration

 Seismic



### Features

- $\pm 2g$  and  $\pm 10g$  range
- Good bias stability (less than 0.1% of full scale)
- Single power supply (+2.5V to +5.5V, ratiometric voltage output)
- Low power
- TO8 packaging ( $\varnothing$  15.55mm x 3.9mm without pin)
- Individually calibrated (bias, scale factor and non linearity)
- Harsh environment (Vibration, shock, temperature)
- RoHS compliant

The MS7000 product is a single axis MEMS capacitive accelerometer based on a bulk micro-machined silicon element designed for generic requirements, a low power ASIC for signal conditioning and a micro-controller for storage of compensation values. The product is low power, fully calibrated at 3V, robust and extremely stable.

It operates from a single power supply voltage (between +2.5V and +5.5V) with low current consumption (< 0.2mA at 3V). The output is a ratiometric analog voltage that varies between +0.5V and +2.5V for the full-scale acceleration range at a voltage supply of +3V. The sensor is fully self-contained and packaged in a TO8, 12 pins housing, thus insuring a full hermeticity.

### Accelerometer specifications

All values are specified at +20°C (+68°F) and 3.0 VDC supply voltage, unless otherwise stated

	Units	MS7002	MS7010
Full scale range	g	$\pm 2g$	$\pm 10g$
Bias calibration	mg	< 10	< 50
One year bias stability @ 6000g [1]	mg typ. (max.)	2 (< 6)	10 (< 30)
Bias temp. coefficient [2]	mg/°C typ.	< 0.1	< 0.5
	mg/°C max.	$\pm 0.4$	$\pm 2$
Scale factor sensitivity (K1)	mV/g	$500 \pm 4$	$100 \pm 1$
One year scale factor stability [1]	ppm typ. (max.)	500 (< 1000)	500 (< 1000)
Scale factor temp. coefficient [2]	ppm / °C typ.	100	100
	min. / max.	-50 / 250	-50 / 250
Input axis misalignment (Kp, Ko)	mrad max.	< 10	< 10
	% max	1	1
Resolution / Threshold (@ 1Hz)	mg max.	< 0.1	< 0.6
Non linearity	% of FS max.	< 0.8	< 0.9
	g max.	< 0.02	< 0.09
Bandwidth [3]	Hz	0 to $\geq 800$	0 to $\geq 650$
Noise spectral density in band (0 ; 9kHz)	$\mu V/\sqrt{Hz}$ typ.	7	7
	max.	18	18
Resonant frequency	kHz	1.4	3.7

[1] One year stability defined according to IEEE 528-2001: turn on / on, storage at -55°C and 85°C, -40°C to 125°C T cycling, -55°C to 85°C unpowered harass, vibration, shock (6000g, single shock).

[2] Temperature coefficients are specified for a range of -40°C to 20°C, where temperature behavior is typically linear and coefficient are maximum.

[3] The bandwidth is defined as the frequency band for which the sensitivity has decreased by less than 3dB.

# DATASHEET

30S.MS7XXX.J.05.11

## Environmental specifications

	MS7002	MS7010
Operating temperature range	-40°C to +125°C (-40°F to 255°F)	
Reliability	Results based on MIL-HDBK-217, notice 2, are available on request.	
Shock resistance	Up to 6'000 g (0.15ms half-sine, single shock, not repetitive, in one direction o, p or i)	
Recovery time	< 1ms (1000g, half-sine period 1ms, shocks in direction i)	
Vibration	20 g rms, 20-2000 Hz (random noise, 30 minutes in each direction o, p, i)	
ESD sensitivity	Class 2 (requirements MIL-STD-883-G, 1 Method 3015.7), Human Body Model 2kV	
Ultrasonic cleaning	The product can't be cleaned with ultrasonic bath. Such a cleaning process will largely affect the sensor integrity	

## Packaging

The packaging is a standard TO8 housing with a total of 12 pins. The precise dimensions are given in the next figure and the weight of the final product is typically smaller than 2.6 grams

The sealing process is qualified according to the MIL-STD-883-G and systematical leak tests are performed up to  $5 \cdot 10^{-8}$  atm·cm<sup>3</sup>/s.

MS7000 side View

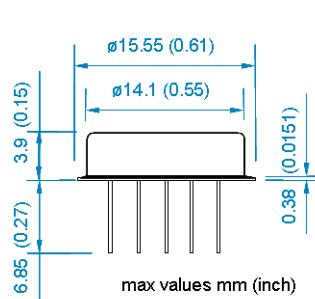

MS7000 top view without lid

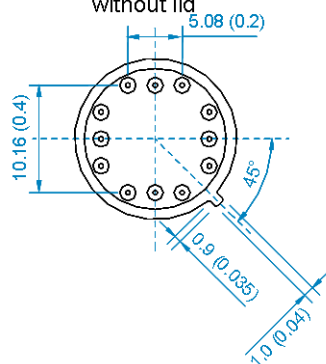

MS7000 side View

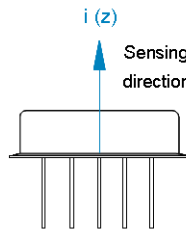

MS7000 top view

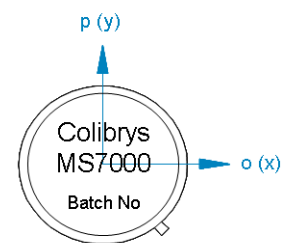

## Mounting

The MS7000 is RoHS compliant. Thanks to the 12 pins through the PCB, the MS7000 is tightly fixed to the PCB, using the bottom of the housing as reference plane to ensure a good axis alignment. The stress induced by the soldering is a specific MEMS concern, especially when it comes to high-end capacitive sensors. In order to obtain good stress homogeneity and the best long term stability, all the pins of the accelerometer must be soldered to the PCB.

## Physical specifications

	MS7002	MS7010
Packaging	TO8, 12 pin housing	
Hermeticity	The product has been qualified according to MIL-STD-833-G. Hermetic sealing is systematically qualified at $5 \cdot 10^{-8}$ atm·cm <sup>3</sup> /s	
Weight	< 2.6 grams	
Size	Max. $\varnothing$ 15.55mm x 3.9mm height without pins ( $\varnothing$ 0.61inch x 0.15inch height without pins)	
Proximity effect	The sensor is sensitive to external parasitic capacitance. Moving metallic objects with large mass or parasitic effect at proximity of the accelerometer (mm range) must be avoided to insure best product performances.	
Reference plane for axis alignment	TO8 must be tightly fixed to the PCB, using the bottom of the housing as reference plane for axis alignment. Using the lid as reference plane or for assembly may affect specifications and product reliability (i.e. axis alignment and/or lid soldering integrity)	

# DATASHEET

30S.MS7XXX.J.05.11

## Principle of operation

The standard calibration voltage for the MS7000.3 is (VDD-VSS) = 3V. Therefore, all specifications are valid for this supply voltage unless otherwise stated. Upon market request, the calibration of the product at a different voltage (between 2.5V and 5.5V) is possible. In such a case, the nominal output signal will vary according to the following equation:

$$V_{out} = (VDD - VSS) / 2 + A_i \cdot (K1 \cdot VDD / 3) \quad (1)$$

$$V_{AGND} = (VDD - VSS) / 2 \quad (2)$$

According to this equation (1), the bias and scale factor are ratiometric to the power supply voltage.

A reference voltage VAGND is also provided at half of the power supply and corresponds to the output voltage at zero g. All sensors are calibrated to match the ideal response curve in term of offset, gain and non-linearity.

At every power-up, the microcontroller, used as memory, transfers the calibration parameters to the ASIC and then goes in a sleep mode. During this initialization phase, which takes less than 50ms, the current consumption goes up to max. 1mA @ 5V and at room temperature. Then, the normal operating current is set and remains less than 200µA under similar conditions.

The following model describes each sensor:

$$V_{out} = k_1 \cdot (k_0 + A_i + k_2 A_i^2 + k_3 A_i^3 + k_p A_p + k_o A_o + k_{ip} A_i A_p + k_{io} A_i A_o + E)$$

where

- $A_i, A_p, A_o$  are the accelerations for each axes of the sensor with:
  - l : input axis (z axis)
  - p: pendulous axis (y axis)
  - o: output axis, also named pivot or hinge axis (x axis)
- $K1$  is accelerometer scale factor [V/g]
- $K0$  is bias [g]
- $K2$  is second order non linearity [g/g<sup>2</sup>]
- $K3$  is third order non-linearity [g/g<sup>3</sup>]
- $Kp$  is pendulous cross axis non linearity [rad]
- $Ko$  is output cross axis non linearity [rad]
- $Kip, Kio$  are cross-coupling coefficients [rad/g]
- $E$  is the residual noise [g]

## Electrical specifications

	MS7002	MS7010
Input voltage (VDD – VSS)	2.5 to 5.5 VDC. The standard voltage for calibration is 3.0 VDC.	
Output voltage range	From 0.5 to 2.5 VDC @ 3.0 VDC input voltage (VDD/2 at 0g)	
Operating current consumption	< 200 µA @ 3.0 VDC	
Initialization & reset current consumption	Typ. 1000 µA @ 3.0 VDC during the initialization phase (less than 50 ms at room temperature)	
Reset	Reset can only be done by a complete switch off of VDD	
Output impedance / load	Min. 50 kΩ at Vout (pin 2) and VAGND (pin 5) Max. 50 pF at Vout (pin 2) and Max. 100 µF at VAGND (pin 5)	

## Temperature compensation

The MS7000 delivers an output signal without any internal temperature compensation.

# DATASHEET

30S.MS7XXX.J.05.11

## Sensor connections and power supply requirements

The detailed block diagram is given in the next figure

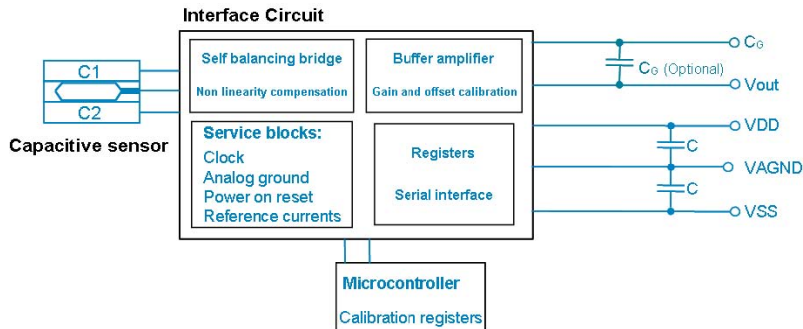

### Components in the TO8 packaging:

- 1-axis silicon MEMS sensor
- ASIC
- Microcontroller

It is strongly recommended to use decoupling capacitors [C] of 1 $\mu$ F each between VDD and VAGND and between VAGND and VSS, placed as close as possible from the accelerometer. COG or X7R @ 5% capacitor types are recommended. On top, the VAGND track should be as short as possible. Any other setup will potentially affect the bias calibration and stability.

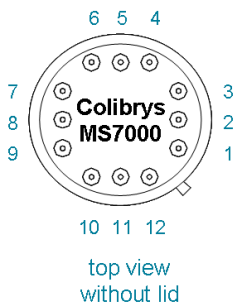

Pin	MS8000 Description	Notes
2	Vout	Accelerometer output signal
3	CG	Bandwidth adjustment
4	VSS	Ground
5	VAGND	Accelerometer output reference voltage (VDD / 2)
6	VDD	Power supply
9	VPP (Colibrys internal calibration pin)	<b>Must</b> be connected to VSS
10	SCK (Colibrys internal calibration pin)	<b>Must</b> be connected to VSS
11	SDA (Colibrys internal calibration pin)	<b>Must</b> be connected to VSS

**Note:** An external capacitor C<sub>g</sub> can be added to reduce the output bandwidth of the sensor. It is anyway recommended to use this option only for development purpose. In production, an external filter will be much more stable over temperature and over time.

## Quality

- Colibrys is ISO 9001:2008, ISO 14001:2004 and OHSAS 18001:2007 certified
- Colibrys is in compliant with the European Community Regulation on chemicals and their safe use (EC 1907/2006) REACH.
- MS7000 products comply with the EU-RoHS directive 2002/95/EC (Restrictions on hazardous substances) regulations.
- MS7000 products are complaints with the Swiss LSPro : 930.11 dedicated to the security of products



### Note:

- MS7000 accelerometers are available for sales to professional only
- Les accéléromètres MS7000 ne sont disponibles à la vente que pour des clients professionnels
- Die Produkte der Serie MS7000 sind nur im Vertrieb für kommerzielle Kunden verfügbar
- Gli accelerometri MS7000 sono disponibili alla vendita soltanto per clienti professionisti
- Recycling : please use appropriate recycling process for electrical and electronic components



# DATASHEET

30S.MS7XXX.J.05.11

## Glossary of parameters of the Data Sheet

### **g [m/s<sup>2</sup>]**

Unit of acceleration, equal to standard value of the earth gravity (Accelerometer specifications and data supplied by Colibrys use 9.80665 m/s<sup>2</sup>)

### **Bias [mg]**

The accelerometer output at zero g

### **Bias stability [mg]**

Maximum drift of the bias after extreme variation of external conditions (aging, temperature cycles, shock, vibration)

### **Bias temperature coefficient [ $\mu$ g/°C]**

Maximum variation of the bias calibration under variable external temperature conditions (slope of the best fit straight line through the curve of bias vs. temperature). Bias Temperature Coefficient is specified between -40°C and +50°C, where temperature behaviour is linear

### **Scale factor sensitivity [mV/g]**

The ratio of the change in output (in volts) to a unit change of the input (in units of acceleration); thus given in mV/g

### **Scale factor temperature coefficient [ppm/°C]**

Maximum deviation of the scale factor under variable external temperature conditions

### **Temperature sensitivity**

Sensitivity of a given performance characteristic (typically scale factor, bias, or axis misalignment) to operating temperature, specified as worst case value over the full operating temperature range. Expressed as the change of the characteristic per degree of temperature change; a signed quantity, typically in ppm/°C for scale factor and g/°C for bias. This figure is useful for predicting maximum scale factor error with temperature, as a variable when modelling is not accomplished

### **Axis alignment [mrad]**

The extent to which the accelerometer's true sensitive axis deviates from being perfectly orthogonal to the accelerometer's reference mounting surface when mounted to a flat surface

### **Resolution, Threshold [mg]**

Value of the smallest acceleration that can be significantly measured

### **Non-linearity [% of FS]**

The maximum deviation of accelerometer output from the best linear fit over the full operating range. The deviation is expressed as a percentage of the full-scale output (+A<sub>FS</sub>).

### **Bandwidth [Hz]**

Frequency range from DC to F-3dB where the variation of the frequency response is less than -3dB or -5% for vibration sensors

### **Resonant frequency nominal [kHz]**

Typical value of the resonant frequency of the mounted system

### **Noise [ $\mu$ V/√Hz]**

Undesired perturbations in the accelerometer output signal, which are generally uncorrelated with desired or anticipated input accelerations

Colibrys reserves the right to change these data without notice.